



Pernambuco
02 SET 2014

Day

GOVERNANÇA DE PROCESSOS – DA ESTRATÉGIA À GESTÃO



Aprimorando os Processos de Suporte Alexandre Feitosa

Promoção:



Organização:



Patrocínio:



Apoio:



Apoio Institucional :





Eugênio Antunes
Presidente da EMPREL



O QUE VEREMOS?

- Institucional
- BPM na Emprel
- Estratégia 2013/2014
- 1ª Etapa
- 2ª Etapa
- A comunicação
- Aprendizado
- Próxima Etapa



Organização:



Patrocínio:



Apoio:



Apoio Institucional:



INSTITUCIONAL

A Empresa Municipal de Informática (EMPREL) é uma empresa pública, dotada de personalidade jurídica de direito privado, com patrimônio próprio, autonomia administrativa e financeira, integrante da Administração Indireta Municipal e é responsável pela execução de serviços de Tecnologia da Informação necessários aos órgãos e entidades da administração direta e indireta da Prefeitura do Recife.

<http://www2.recife.pe.gov.br/secretarias-e-orgaos/orgaos/emprel/>

Criada em 9 de dezembro de 1969, tem como Missão:

“Participar da proposição e do gerenciamento das políticas de Tecnologia da Informação e Comunicação - TIC da Prefeitura do Recife e prover soluções sob medida, com credibilidade e excelência no atendimento, com foco nos interesses da administração da cidade e na democratização dos meios de acesso à informação”.

Quadro de Pessoal: 297 (144 lotados na área fim).



Organização:



Patrocínio:



Apoio:



Apoio Institucional:



INSTITUCIONAL

Clientes (41)

- Gabinete do Prefeito
- Gabinete do Vice-Prefeito
- Gabinete de Representação em Brasília
- Gabinete de Projetos Especiais
- 24 Secretarias (Administração direta)
- 13 órgãos (Entidades supervisionadas)



<http://www2.recife.pe.gov.br/secretarias-e-orgaos/gabinetes/gabinete-do-prefeito/>

Sistemas: Mais de 100

Orçamento: R\$56.000.000,00 (média anual dos últimos dez anos)

Emprel

Organização:



Patrocínio:



Apoio:



Apoio Institucional:



BPM na Emprel

Maio de 2013: A Diretoria Administrativa e Financeira - DAF criou o Projeto BPM-DAF com o objetivo de conhecer e mapear os processos Administrativos e Financeiros da Empresa. Foram priorizados sete dos mais de trinta processos
(**Capacitação, Compras, Contratos, Execução Orçamentária, Financeiro, Folha e Licitação**).

Agosto de 2013: Como parte da capacitação, as Equipes do Projeto BPM-DAF participaram do BPM-Day.

Novembro de 2013: Foi concluída a 1ª etapa do Projeto BPM-DAF.

Dezembro de 2013: Foi iniciada a 2ª etapa do Projeto BPM-DAF.

Julho de 2014: Foi concluída a 2ª etapa do Projeto BPM-DAF, com a modelagem e simulação dos sete processos.

Os resultados obtidos com o Projeto BPM-DAF e a ampliação das práticas de BPM em alguns setores da EMPREL, fizeram com que a GOVERNANÇA CORPORATIVA assumisse as atribuições relacionadas a BPM com o objetivo de definir as diretrizes relativas a esse modelo de gestão e sua consolidação na Empresa.

Emprel

Organização:



Patrocínio:



Apoio:



Apoio Institucional:



Estratégia 2013/2014 para disseminar a cultura de BPM na Emprel

Sensibilização

- Realização de um workshop sobre Modelos de Qualidade (CMMI, MPS-BR, ISO e BPM). Participaram do workshop a academia (UFRPE), empresas de consultoria e a Emprel.

Formação do Grupo de trabalho

- Diretor da DAF,
- Chefe de Departamento de Gestão de Pessoas
- 01 Analista de processos,
- 01 Analista Organizacional e
- 01 Analista de Finanças e Contabilidade



Estratégia 2013/2014 para disseminar a cultura de BPM na Emprel

Além do grupo de trabalho, 28 empregados estiveram diretamente envolvidos, representando a DAF, a Comissão Permanente de Licitação – CPL e a Assessoria Jurídica, totalizando 33 pessoas (14 % dos 224 empregados lotados na sede da empresa).



Elaboração e aprovação do plano do projeto (maio de 2013).



1ª Etapa* (maio/novembro 2013)

- Levantamento de todos os processos da DAF (31)
- Priorização dos processos que seriam trabalhados (7):
 - ❖ compras, licitação, contratos, folha, capacitação, orçamentário e financeiro
- Mapas dos 7 processos
- Checklists (entradas e saídas dos processos)
- Indicadores dos 7 processos (3 para cada processo)
- Manual para cada processo
- Definição dos Gestores dos processos
- Definição dos Donos dos processos
- Criação dos e-mails corporativos para encaminhamento das demandas, em cada processo



*Não fêz parte do escopo a automação dos processos

Emprel

Organização:



Patrocínio:



Apoio:



Apoio Institucional:



1ª Etapa (maio/novembro 2013)

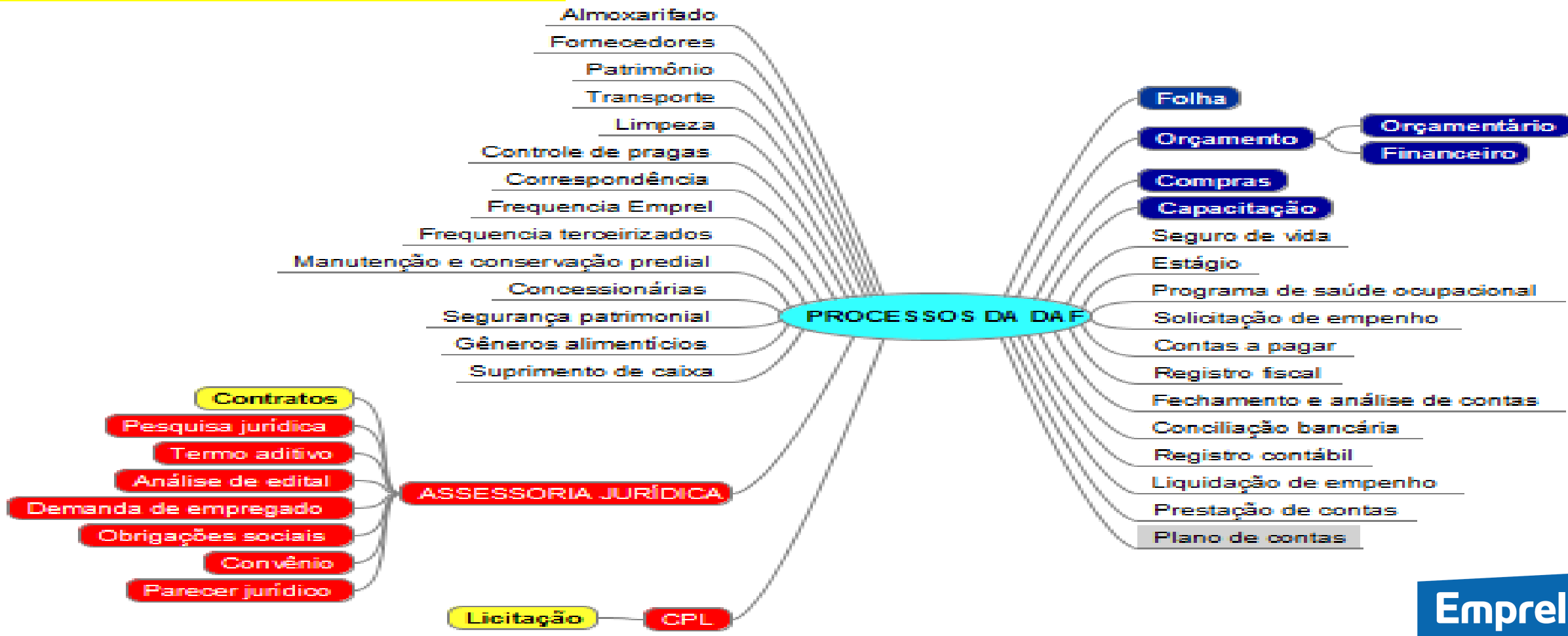

1ª Etapa (maio/novembro 2013) - resultados

- Atendimento de 100% previsto no Escopo

- Capacitação
 - ✓ Curso de Introdução ao BPM (interno)
 - ✓ Curso de formação de analistas de processos (externo)
 - ✓ Curso de modelagem e simulação de processos (externo)
 - ✓ Curso de formação de especialista em automação de processos com BPMS (externo)
 - ✓ BPM DAY-2013
 - ✓ 109 empregados tiveram alguma orientação sobre BPM em 2013 (48% dos 224 empregados lotados na sede)
 - ✓ Investimento = R\$29.000,00 (R\$266,00 por empregado)



2ª Etapa* (dezembro/2013 a julho/2014)

- Maior detalhamento dos mapas dos processos (modelagem)
- Revisão das atividades dos processos
- Alocação dos recursos para cada atividade
- Relação das ações de cada atividade
- Simulação dos processos
- Atualização do Manual de cada processo



*Não fez parte do escopo a automação dos processos

Organização:



Patrocínio:



Apoio:



Apoio Institucional:



2ª Etapa (dezembro/2013 a julho/2014) - resultados

- Atendimento do previsto no Escopo
- Capacitação de Gestores e Donos dos Processos
 - ✓ Curso de modelagem e simulação de processos (externo)
- Inclusão de Planilha de Monitoramento dos Indicadores dos 7 Processos
- A Equipe atingiu maior grau de maturidade em BPMN e uso da ferramenta de BPMS
 - ✓ funcionalidade “Simulação”



A comunicação



Emprel RECIFE PREFEITURA DA CIDADE

A EMPREL | Produtos e Serviços | Carteira de Clientes | Enquetes | Webmail | Contato | Login

Pesquisar

Participação nos Lucros e Resultados - PLR

Enviado por admin em sex, 06/07/2012 - 14:38.
MODELO: Baseado no alcance de metas estabelecidas pela empresa.

O Programa de Participação nos Lucros e Resultados - PLR visa estimular os colaboradores da Emprel a atingirem metas estabelecidas pela empresa, e em contrapartida, se habilitarem a receber um recurso financeiro extra. Veja abaixo os detalhes do programa.

- Legislação do PLR

Por favor, [faça o login](#) para enviar comentários [Leia mais](#)

PDI 2013 - Conceitos, Cronogramas, Metodologia e Resultados

[Conceito](#) [Gestão por Competências](#)

[Leia mais](#)

BPM DAF

O relatório abaixo apresenta informações relativas á execução do projeto para mapeamento, redesenho e proposição de melhorias no macroprocesso Administrativo-Financeiro da Emprel.

[Leia mais](#)

Cidadão Inteligente: criatividade à serviço da população



A comunicação



Boletim Informativo

06/08/2014

BPM-DAF é apresentado

Participaram, direção, gestores e funcionários da empresa

Foto: Inês Dowsley



Organização:



Patrocínio:



Apoio:



Apoio Institucional:



A comunicação

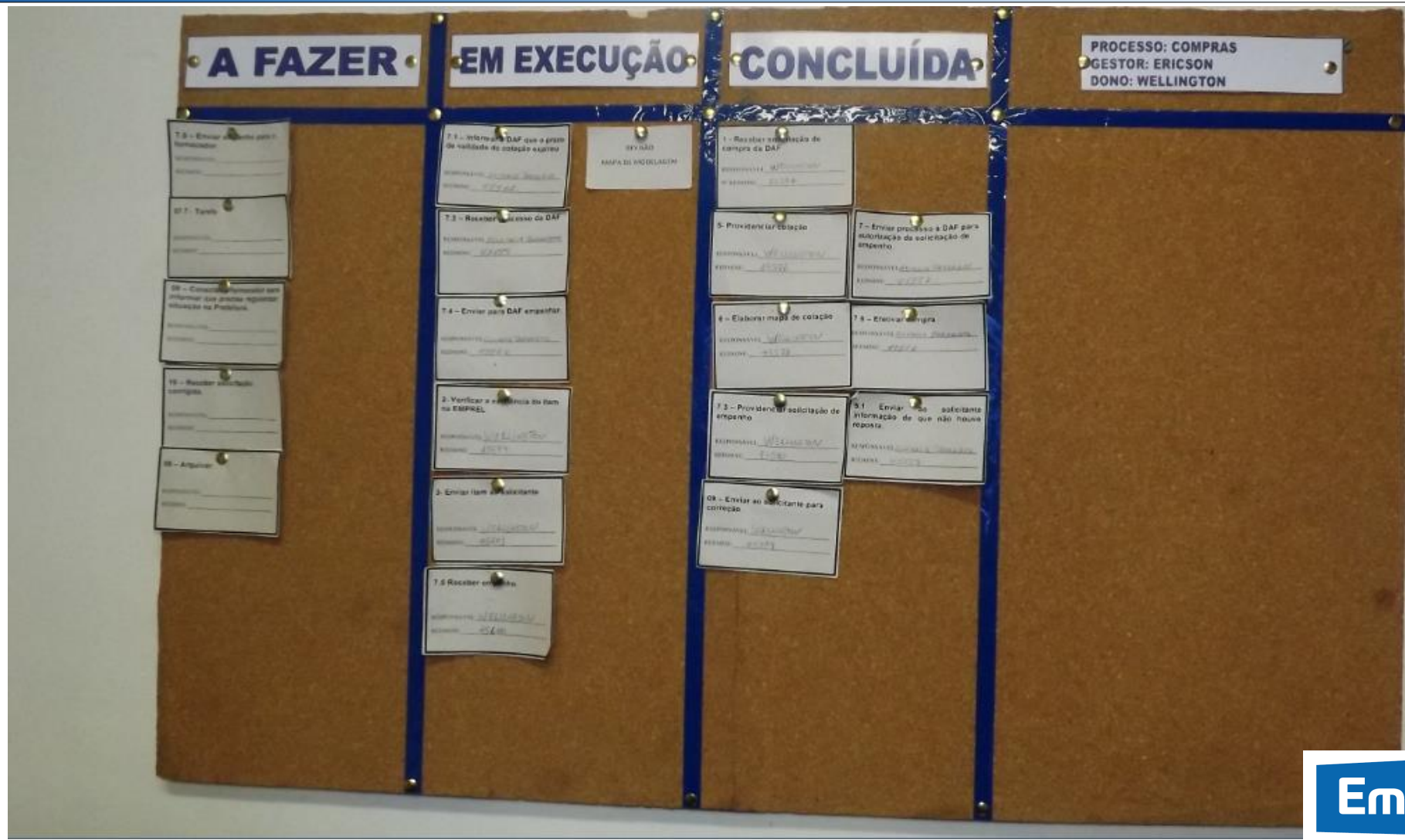

Aprendizado

- Importância do patrocínio da Direção da Empresa
- A efetiva comunicação interna e externa sobre o Projeto como elemento de integração entre os setores da Empresa
- A importância da capacitação das pessoas envolvidas em cada processo
- Constatação da importância da responsabilidade das pessoas envolvidas na elaboração/execução do Projeto
- A implantação da Gestão do Conhecimento através de BPM
- Para a Empresa valeu o esforço despendido no Projeto para conhecimento do potencial de sua equipe e do desempenho dos seus processos.



Emprel

Organização:



Patrocínio:



Apoio:



Apoio Institucional:



Próxima Etapa

- Disponibilização dos 7 Processos Modelados/Simulados no Portal da Empresa;
- Disponibilização dos Manuais, Checklist e Indicadores dos 7 Processos no Portal da Empresa;
- Implantação da Planilha de Monitoramento dos Indicadores dos 7 Processos (AGC e DAF);
- Implantação da Auditoria, nos 7 Processos, para verificar o grau de adesão das Atividades/Ações;
- Definição do MACRO PROCESSO DE AQUISIÇÃO, a partir dos processos: Compras, Licitação e Contratos e
- Revisão da relação de todos os Processos da DAF.





Grupo Coordenador do Projeto





Reunião de nivelamento



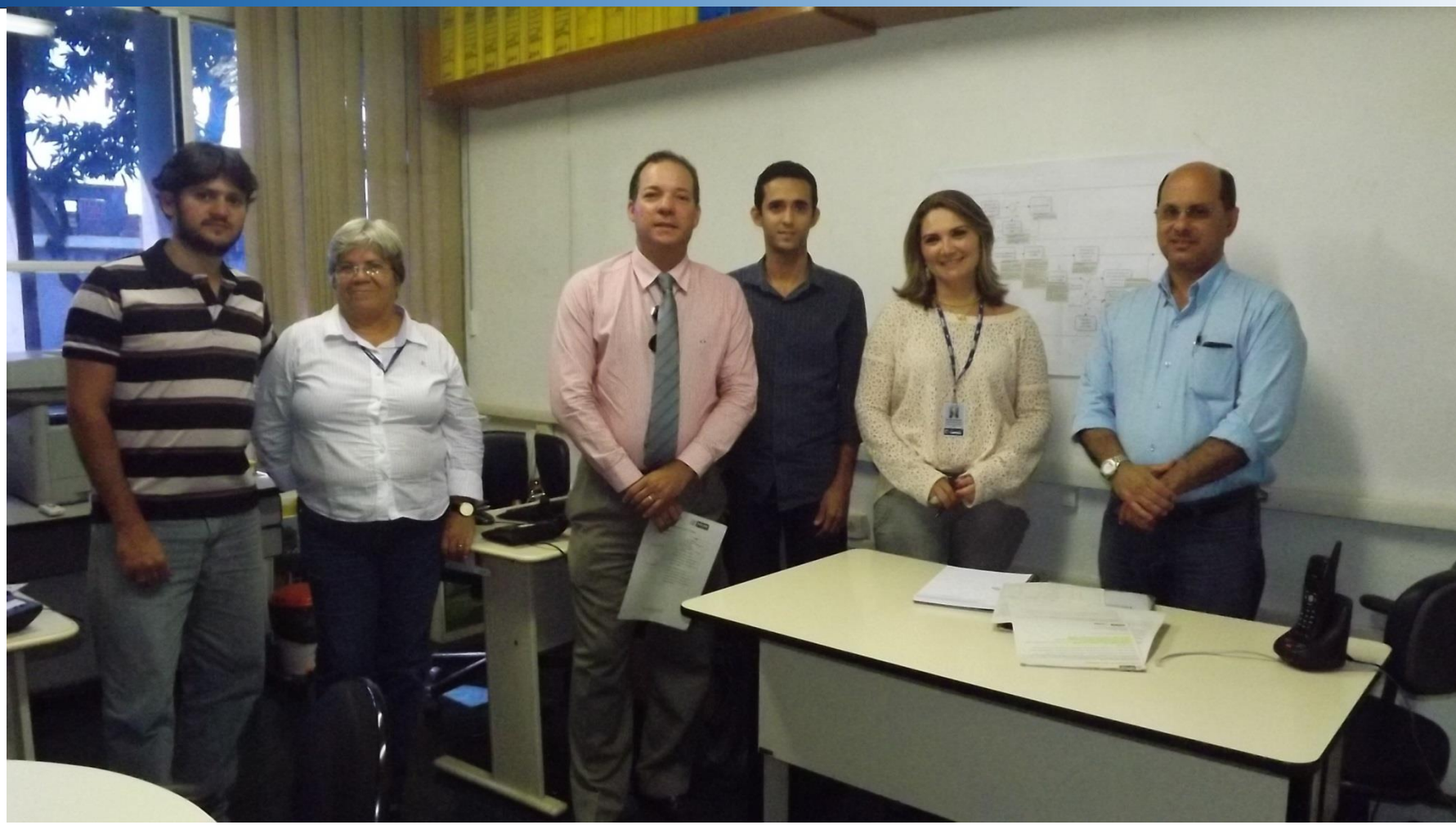

Equipe do Processo de Compras

Gestor: Ericsson

Dono: Ana Dulce



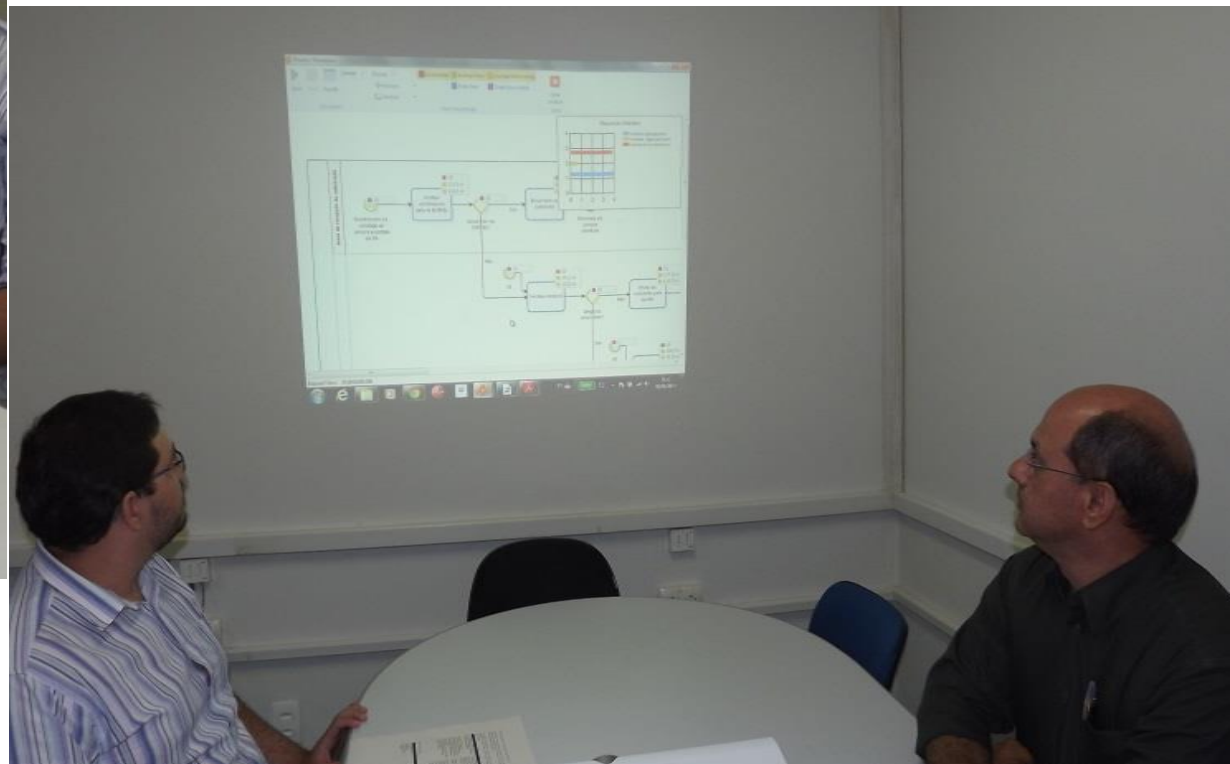

Dia que executamos a 1ª simulação (processo de Compras) – 08.04.2014



Emprel



BPM COMPRAS- UOAD

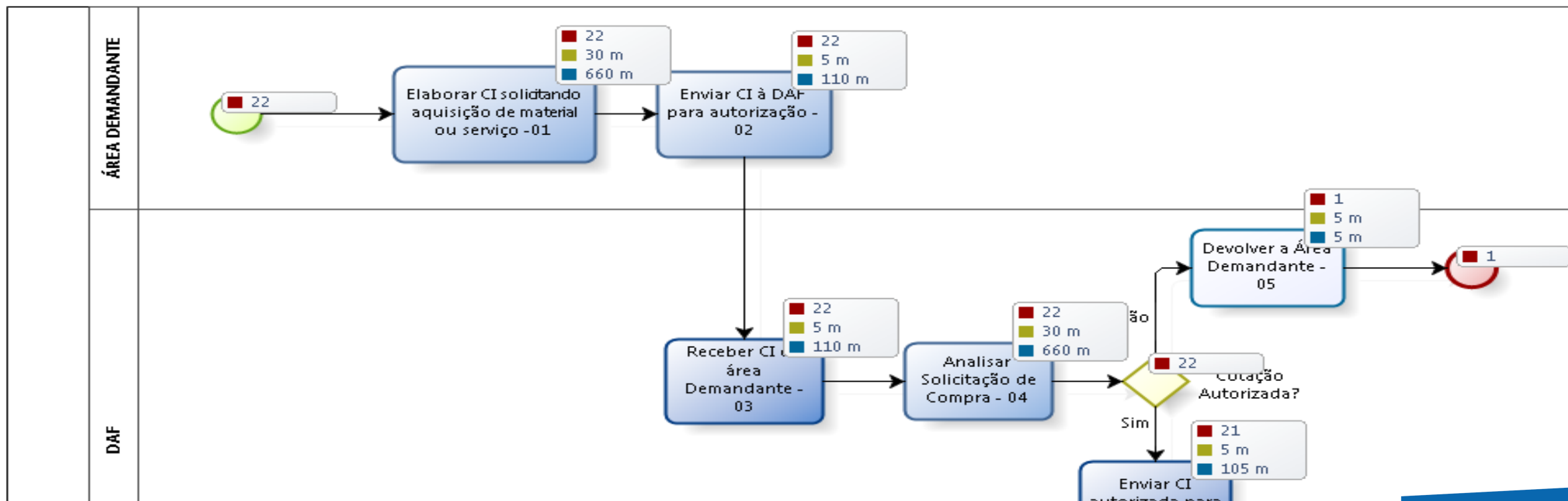

Simulação do processo de Compras

Emprel

Organização:

Patrocínio:

Apoio:

Apoio Institucional:





Equipe do Processo de Licitação

Gestor: Tai Mu Shih

Dono: Fernando Ramos



Organização:

Patrocínio:

Apoio:

Apoio Institucional:



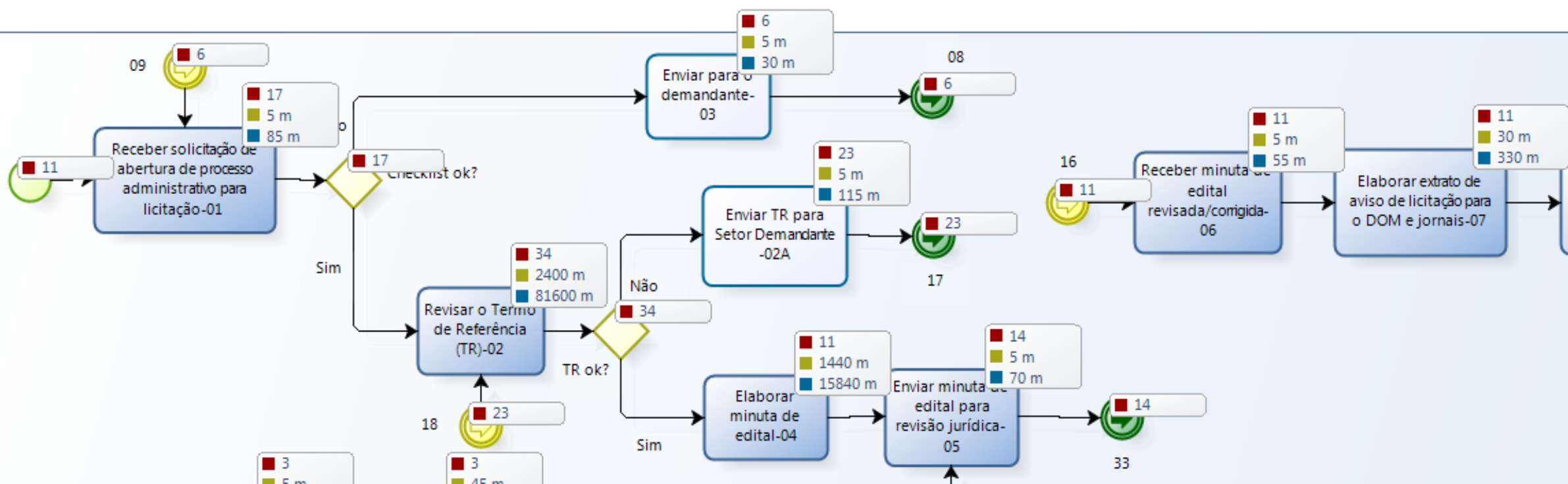

Simulação do processo de Licitação





Equipe do Processo de Contratos

Gestor: Alexandre Feitosa

Dono: Lúcia Araújo





BPM CONTRATOS- UOAD

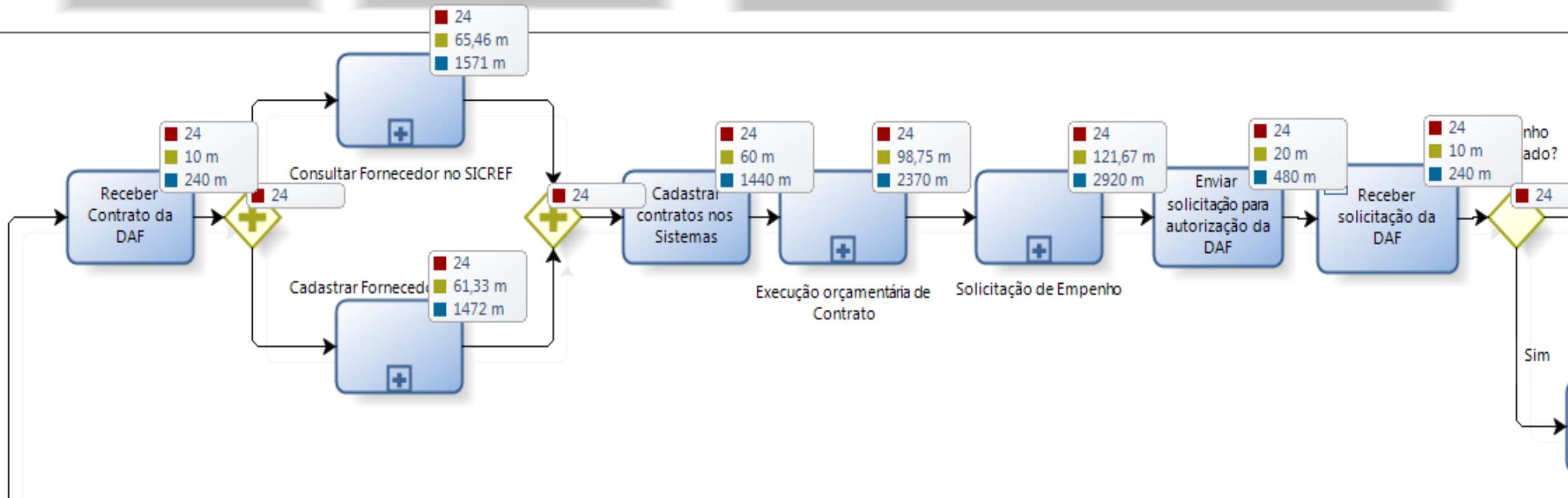

Simulação do processo de Contratos



Organização:

Patrocínio:

Apoio:

Apoio Institucional:





Equipe do Processo de Capacitação

Gestor: Ivaldo Rufino

Dono: Maria Vitória



Organização:



Patrocínio:



Apoio:



Apoio Institucional:



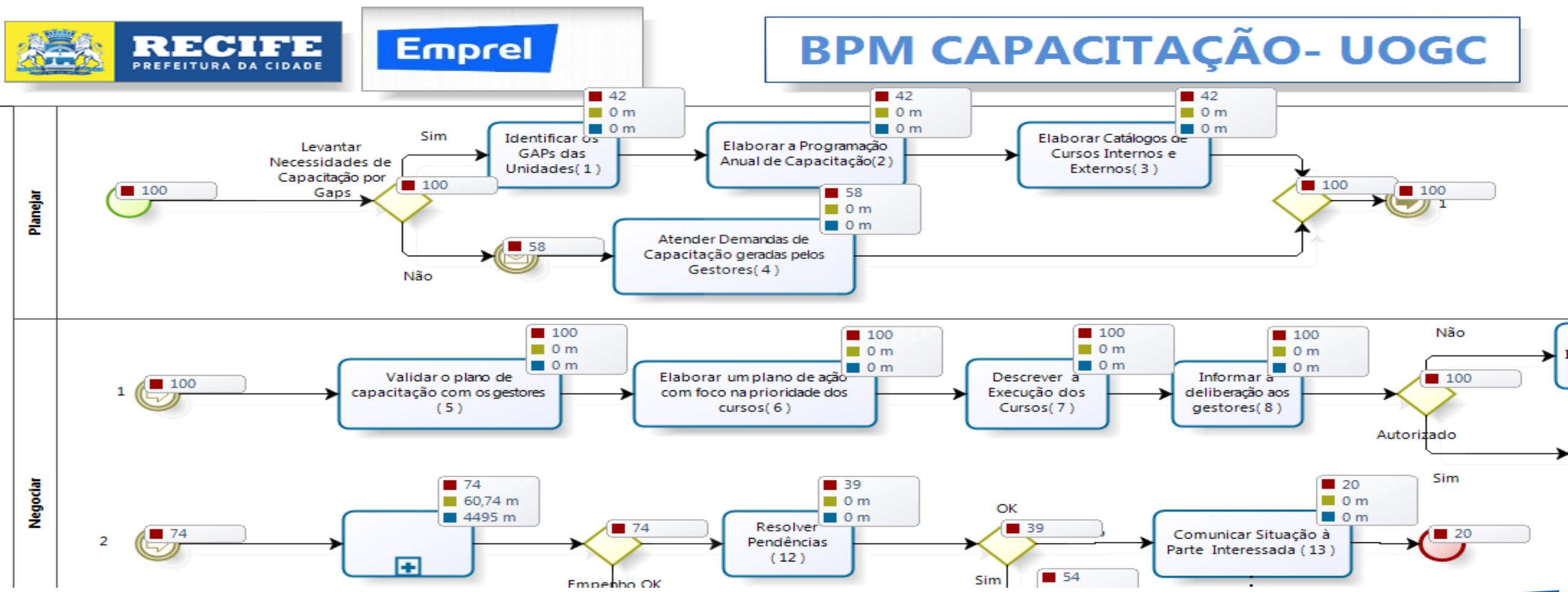

Simulação do processo de Capacitação





Equipe do Processo de Folha

Gestor: Ivaldo Rufino

Dono: Armindo Maciel





BPM FOLHA- UOCF

UOCF - LANÇAMENTOS

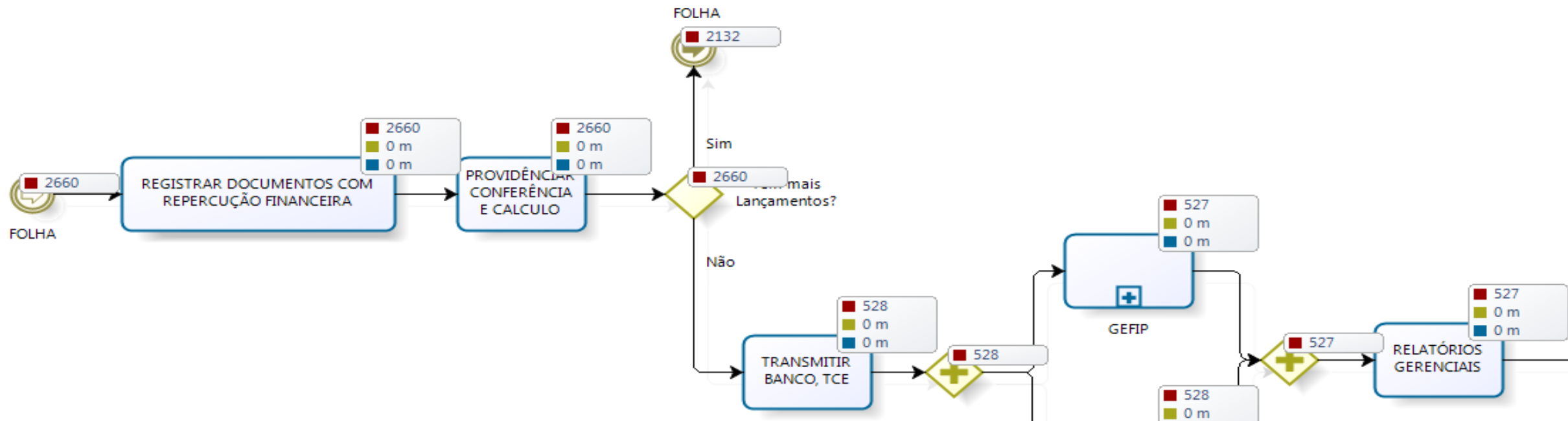

Simulação do processo de Folha





Equipe do Processo Orçamentário

Gestor: Alexandre Feitosa

Dono: Mônica Maria



Organização:



Patrocínio:



Apoio:



Apoio Institucional:





BPM EXECUÇÃO ORÇAMENTÁRIA- UOFI

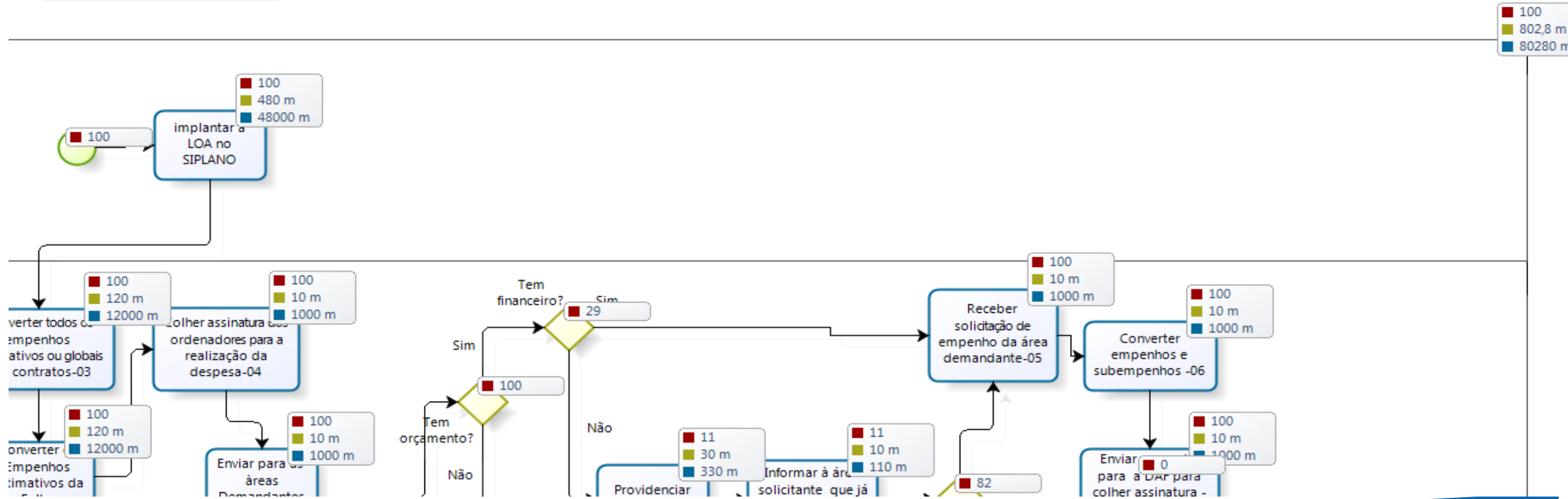

Simulação do processo Orçamentário



Organização:

Patrocínio:

Apoio:

Apoio Institucional:





Equipe do Processo Financeiro

Gestor: Alexandre Maciel

Dono: Marcelo Guerra



Organização:



Patrocínio:



Apoio:



Apoio Institucional:



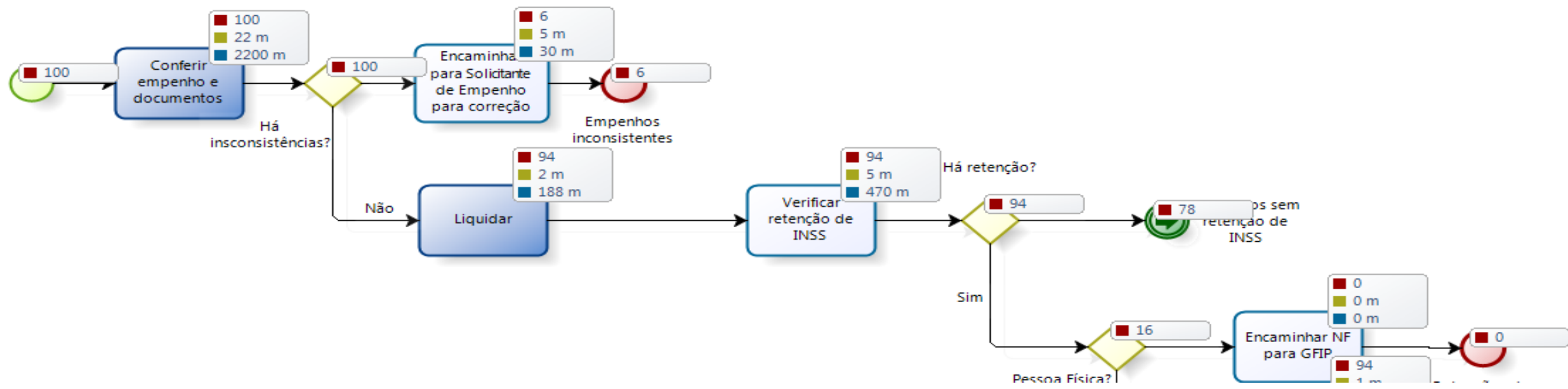

Simulação do processo Financeiro



PROCESSO DE COMPRAS

MODELAGEM



Organização:



Patrocínio:



Apoio:



Apoio Institucional:



Emprel



BPM COMPRAS- UOAD

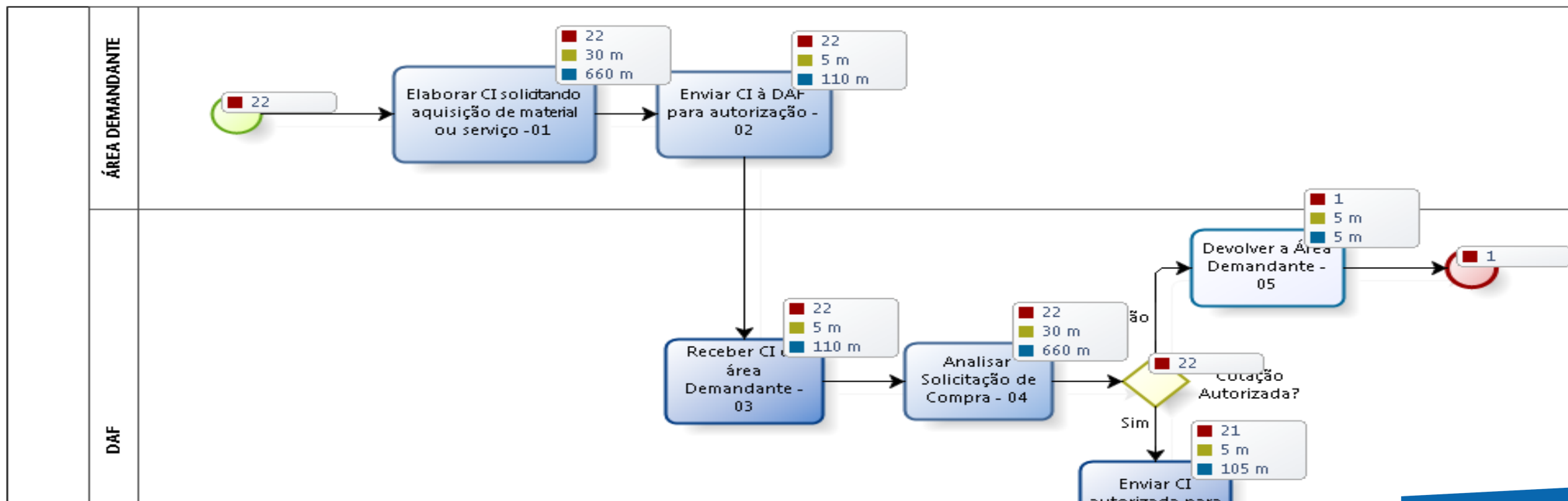

Simulação do processo de Compras

Emprel

Organização:

Patrocínio:

Apoio:

Apoio Institucional:



A voz de quem fêz...



Organização:



Patrocínio:



Apoio:



Apoio Institucional:



Buscar sempre a Melhoria...

**”Se existe uma
forma de fazer
melhor...
descubra-a”.**

Thomas Edison



Emprel

Organização:



Patrocínio:



Apoio:



Apoio Institucional:



REFERÊNCIAS

ABPMP. Guia para o Gerenciamento de Processos de Negócio. Corpo Comum de Conhecimento BPM CBOOK . Versão 3.0. 1ª Edição. ABPMP-Brasil, 2013.

CAPOTE, Gart. Medição de Valor de Processos para BPM – Perspectivas, Ferramentas e Métodos para Maximizar o Verdadeiro Valor dos Processos. 1ª Edição. Rio de Janeiro: Gart Capote, 2013.

CAPOTE, Gart. Guia para Formação de Analistas de Processos – BPM Volume I / Gart Capote de Britto. 1ª Edição. Rio de Janeiro: Gart Capote, 2011.

ROSEMANN, Michael. BROCKE, Jam vom. Manual de BPM – Gestão de processos de negócio. Porto Alegre: Bookman, 2013.

Emprel

Organização:



Patrocínio:



Apoio:



Apoio Institucional:



BPM

Pernambuco
02 SET 2014

Day

GOVERNANÇA DE PROCESSOS –
DA ESTRATÉGIA À GESTÃO

Obrigado!

Alexandre Feitosa

alexandre.feitosa@recife.pe.gov.br

81 3355-7041

Promoção:



Organização:



Patrocínio:



Apoio:



Apoio Institucional :

